

Long-stroke transducer with sleeved core

for hydraulic and pneumatic cylinder applications

WP (pressure-proof up to 320 bar)

MESSOTRON

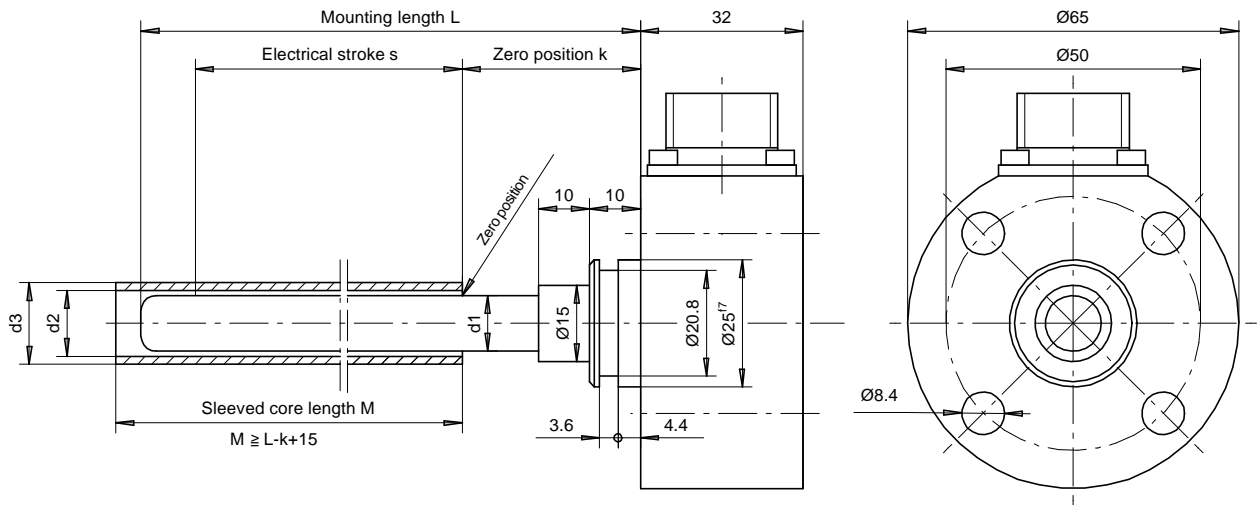

radial wire interface

Teflon® cable 2.5 m long

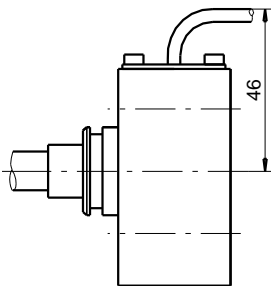
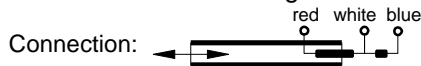

Example: WP 300 Q

radial connector interface

mating connector supplied

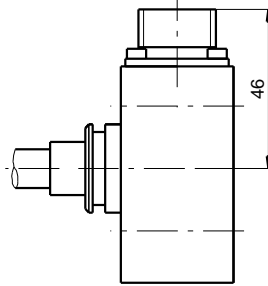
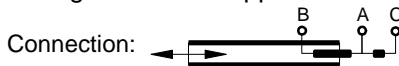

Example: WP 300 R

axial connector interface

mating connector supplied

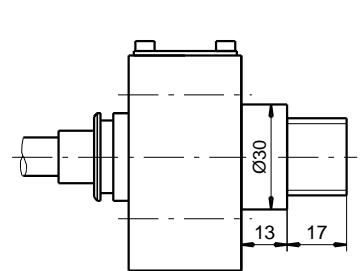
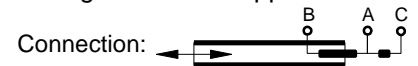

Example: WP 300 AX

		WP 60	WP 120	WP 160	WP 200	WP 300	WP 400	WP 500	WP 600	WP 800	WP 1000
Nominal stroke	mm	60	120	160	200	300	400	500	600	800	1000
Maximum stroke	mm	70	130	180	230	330	430	530	650	880	1100
Mounting length L	mm	120	190	235	310	410	510	610	750	1000	1250
zero k	mm	35	35	35	45	45	60	60	60	80	80
Transducer diameter d1	mm	11	11	11	11	11	12	12	12	12	12
Sleeved core diameter d3/d2	mm	16/13	16/13	16/13	16/13	16/13	18/14	18/14	18/14	18/14	18/14
Sleeved core length M	mm	120	190	235	310	410	510	610	750	1000	1250
Transducer weight	g	700	730	750	800	900	1000	1100	1200	1300	1500
Sleeved core weight	g	30	40	50	60	80	150	190	230	280	350
Nominal output signal	mV/V	27	40	55	32	30	30	30	30	30	36
Excitation voltage		1 ... 5 V _{eff}									
Excitation frequency		5 kHz									
Static resolution		virtually infinite									
Recommended amplifier		MBI 46.31 or MBI 50.33									
Linearity		±0.5% F.S.O									
Temperature coefficient of zero		±0.2% / 10K; for Option 120°C: >100°C: typ. ±1% / 10K									
Temperature coefficient of span		±0.2% / 10K; for Option 120°C: >100°C: typ. ±1% / 10K									
Pressure resistance		operating pressure 320 bar, test pressure 500 bar									
Operational temperature		-20°C ... +80°C Option: up to 120°C *)									
Protection class (DIN 40050)		IP 65									

*) select option for ordering

MESSOTRON
Hennig GmbH & Co. KG
Industrie-Messtechnik
Friedr.-Ebert-Str. 37, Tel.: (06257)82331
D-64342 Seeheim-Jugenheim

WP Series
60 ... 1000 mm

Drawing
17.10.01

Date 05/2004
Previous issues 17.10.12/15/17

Design of transducers can be customised

Subject to change without prior notice

05/2004