

Tracker 321/331 for PID Control

The Tracker 330 series is a fully featured PID controller providing genuine single loop integrity to a plant control system. The controller features an auto-tune function for automatic setting of the P, I, D and Heat/Cool relative gain values.

Features

- Auto-tune PID or On/Off control
- Reverse, Direct and Heat + Cool control actions
- Pulse Width Modulation (PWM) logic control outputs
- Universal Input for Thermocouples, RTD, mV, Volts and mA
- RS485 Communications, 4 protocols including Modbus RTU
- Universal 90–265V AC supply
- One Relay and one SSR output (can be for alarms or PID control)
- 10V/24V DC sensor excitation supply
- Thermocouple condition monitoring
- Communication loss “self protection” modes
- Partial load and load condition monitoring*

Tracker 331

- ✓
- ✓
- ✓
- ✓
- ✓
- ✓
- ✓
- ✗
- ✓
- ✓
- ✓
- ✓
- ✓

Tracker 332

- ✓
- ✓
- Using T340
- ✓
- ✓
- ✗
- ✓
- ✓
- ✓
- ✓
- ✓
- ✓
- ✓

*Requires an external current transmitter (one PWM control output only)

Note: To use the Tracker 332 as a PID controller the analogue output option and/or the Tracker 340 logic expansion module must be fitted.

Options

- Second relay output (replaces SSR Output – Tracker 331 only)
- 24V AC/DC supply
- Analogue output (can be used for measurement re-transmission or PID control)
- 4 extra logic outputs (e.g. relays) and 2 logic inputs (Tracker 340)

Typical Tracker 331 Application

Thermocouple Ageing

The Tracker 300 can be used to provide thermocouple sensor condition monitoring. An alarm is set if the sensor may have reached the end of its reliable life; this enables planned pro-active maintenance. Should the thermocouple break, the output power will be fixed at a pre-set value until the sensor is replaced.

Load Monitoring

By using an external current transmitter, the load current is fed back to the Tracker 330. Should one of the heater elements fail the Tracker will indicate a partial load failure alarm. The load monitor can also check for overloads (e.g. heater short circuit) and ensure that the switching device is not passing current when in the off state.

The load current can be scaled to engineering units (e.g. amps) and read in real time via the serial interface. The mean (averaged) current can also be calculated and read in real time.

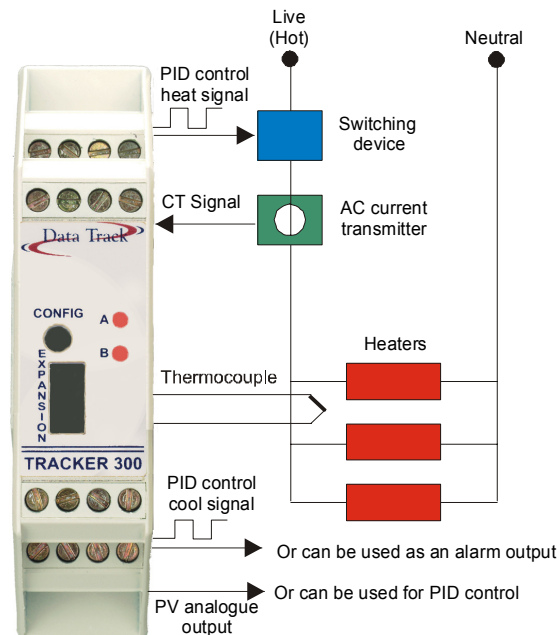

Note: Load monitoring is only available on one PWM (logic) control output.

Multi-loop Control

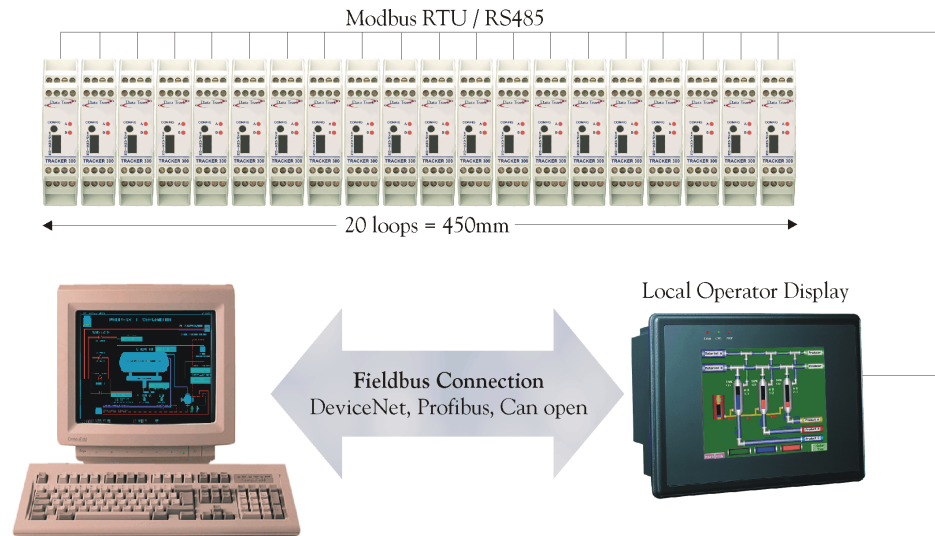

In the 20-zone multi loop control example above the system designer is free to choose the preferred display, communications and control strategy for the application. In this example the local operator display also acts as a Fieldbus interface. Each loop is directly powered and can provide sensor power where appropriate (e.g. two wire transmitters).

Tracker 340 Logic Expansion Module

The Tracker 340 logic expansion module provides the Tracker 331 with up to 6 logic outputs and the Tracker 332 with up to 4 outputs. These outputs can be used for PID control or alarm purposes. The Tracker 340 provides relay or TTL outputs and two logic inputs.

The logic inputs offer special functions that can be activated from an external volt free contact or a TTL interface. These functions include:

- Auto/Manual
- Integral Hold
- PID 1/PID 2 selection switching between two Setpoints, each with their own PID settings

Communication Failure – Self Protection Modes

The “Master” device (e.g. SCADA, PC or HMI station) would normally poll the Tracker 330 “slaves” on a regular basis. If a Tracker 330 does not receive a valid command for a time period pre-set by the user, the PID self-protection can be initiated. The pre-programmed modes are:

- None** – No self-protection, continues controlling normally.
- Power** – Set the control outputs to a pre-programmed “self protection” power level.
- Setpoint** – Control normally but at a pre-programmed “self protection” setpoint.
- Off** – Switch all control outputs off.

Front Panel Engineering Access

The front panel configuration socket can be used should any engineering changes be required to a particular Tracker 300; this can be achieved without disturbing any other devices on the same RS485 link. A special cable is used to connect the socket marked “Config” on the Tracker 300 front panel to an RS232 serial interface. The RS485 interface is disconnected during the use of the configuration socket.

The RS485 interface also allows full access to configuration and real time data values using Modbus RTU or DTPI ASCII protocol. PC compatible configuration software is provided with each unit and can be used via either the “Config” front panel jack plug socket or the RS485 serial interface.

