

Tracker 300 for Signal Conditioning, Isolation & Alarms

Signal Conditioning

Signal conditioning is an important requirement for process plant control systems. It allows plant sensor outputs to be converted to higher level signals (e.g. 4–20mA) so that electrical interference is reduced and accuracy is not affected by long wiring distances. Signal isolation prevents earth loops that can cause measurements to be noisy or even unreadable. Earth loops can occur at any time!

Any of the Tracker 300 series can become a signal isolator and conditioner. The Tracker is configured for the signal or sensor type to be measured and scaled to the engineering units required. The user then selects the measurement engineering unit values that correspond to the zero and span of the selected output range.

Example: Type K Thermocouple signal conditioner
0–150°C = 4–20mA Output

Input = Type K thermocouple
Engineering units = °C



Output Type = 4–20mA
Zero = 0 (°C)
Span = 150 (°C)

- The analogue output uses the measured (linearised) value so the 4–20mA signal is linear to temperature
- The resolution of the analogue output is 15bit (1 part in 32768)
- An 18 point custom linearisation feature allows accurate tank volume measurements
- The analogue output can also be set to transmit the Max (Peak), Min (Valley) values or can be controlled directly via the RS485 interface
- Thermocouple ageing capability (see separate PID application note)

The user can select the analogue output signal type required:

- 4–20 mA** The output will always be between 4–20mA even if the measurement is out of scaled limits. (e.g. If the signal is lower than the scaled range the output will remain at 4mA)
- 0–20mA** The output will reduce to 0mA and will saturate at approximately 24mA if the signal is higher than the scaled range. A 4–20mA output can still be simulated/scaled with this output range type.
- 0–10V** The output will reduce to 0V and will saturate at approximately 12V if the signal is higher than the scaled range.

The analogue output can also be used for PID control output. See separate application note Tracker 300 for PID Control

Signal Isolation

The Tracker 300 series power supply is fully isolated, as is each input and output including the RS485 communications interface.

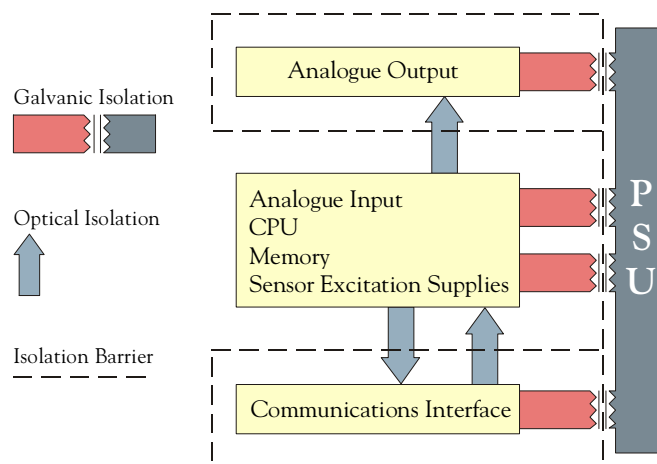

Alarm Outputs

The Tracker 300 can be used as a trip amplifier by using either the dual relays on the Tracker 331, or by connecting a Tracker 340 logic expansion module to any Tracker 300 series unit. The Tracker 340 module provides four logic outputs (relay or TTL) and two logic inputs and it is powered and controlled by the Tracker 320/330 unit. When connected to a T331 a total of six alarm outputs is available.

Each of the alarms can be configured for any of the following functions:

- Setpoints adjustable over whole measurement range
- High, Low or Deviation (band) alarm action
- Independent high and low deviation values for band alarm
- Programmable on and off delay timers to avoid short term "fleeting" alarms
- Programmable hysteresis, set in engineering units
- Latching or automatic reset
- Outputs can be energised or de-energised when in the alarm condition
- Corresponding front panel LEDs follow the output state or alarm condition
- One alarm can control more than one output
- Outputs can be used for both load monitoring and thermocouple condition alarms
- Each relay provides independent volt free change over contacts
- Programmable alarm inhibit for "start up" conditions (alarm blocking)
- Outputs can be remotely controlled via the RS485 serial interface
- Outputs can be selected for use with PID control

See application note Tracker 300 for PID Control

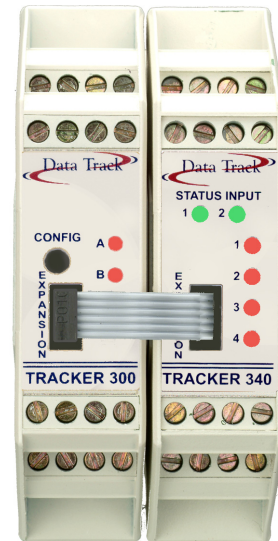

Note: The alarms are available in the Tracker 300 software via the serial communications interface even if a Tracker 340 module is not fitted.

Logic Inputs (Tracker 340)

Fitting the Tracker 340 Logic Expansion Module also provides two logic inputs. The state of the logic inputs can be read via the serial communications interface. These logic inputs can also be configured to perform special functions when active:

- Tare
- Zero
- Reset Max / Min memory
- Alarm Disable (forces all alarms to their non-alarm state)
- Alarm Acknowledge (resets latched alarms if the alarm condition has cleared)
- Analogue output hold
- Measured value hold

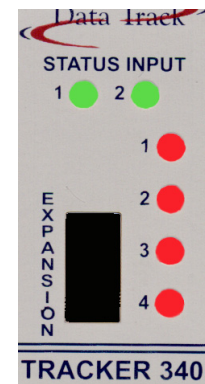

There are further functions available on the 330 series relating to PID control.

See separate application note Tracker 300 for PID Control

Using the Tracker 331 as a Combined Dual Alarm Trip and Signal Transmitter

The Tracker 331 can have two alarm relay outputs (replaces the SSR drive output). Fitting a Tracker 340 to a Tracker 331 allows 6 outputs to be available.

- Universal Input*
- 2x Relays with independent normally open contacts
- Isolated analogue output.

Fitting the analogue output option makes the Tracker 331 an ideal combined dual alarm trip and isolating transmitter.

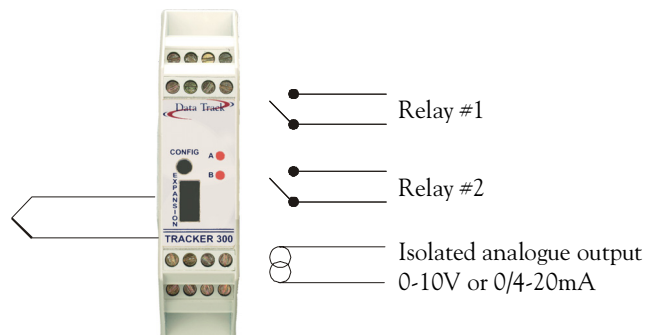

*24V and 10 V excitation supply outputs are not available on the T331